

# Briefing on the technical specification for General Packet Radio Services (GPRS) and Wideband Code Division Multiple Access (WCDMA) systems.



## GPRS - The Basic Principle

General Packet Radio Service (GPRS) provides a means for a data connection to be maintained without continuous transmission of signals except when data is being passed to or from the terminal. This is a similar concept for data to discontinuous voice feature is for speech - but with fewer signals needed to maintain the call during no-data periods.

A GPRS-enabled terminal operates in a similar fashion to a standard GSM terminal with a few basic differences. Where a network base station carrier frequency is subdivided into eight Tx/Rx time slots and these can be allocated to eight GSM terminals, a GPRS terminal has the ability to use multiple consecutive time slots to achieve a greater data transmission or reception rate.

The theoretical limit on this would be to utilise eight time slots, however, this is not desirable from either the terminal user's perspective or the network operator's. The mobile terminal would demand a high power drain from the battery that could result in short battery life. A network operator may find it difficult to offer a GPRS eight time slot service as this would require considerable excess capacity to be distributed across the network to account for user demand.

Most current applications of GPRS are based around higher volumes of data being received by the terminal than being sent by the terminal, e.g. web browsing and WAP type services. Thus the initial terminal offerings on the market are based on one or two time slot transmit with a two to four time slot receive allocation. However, some PC cards may have up to four time slot uplink capability subject to support from the network.

## Relevant GPRS Technical Standard

3GPP TS 05.02 V6.9.2 (2001-4)

### Power Class<sup>1</sup>

GSM/GPRS equipment or mobile phone handsets (MS) are limited to the following maximum power outputs.

Power Class	Nominal Max Power GSM 900	Nominal Max Power PCS 1800	Tolerance
1		30 dBm	±2 dB
2	39 dBm	24 dBm	±2 dB
3	37 dBm	36 dBm	±2 dB
4	33 dBm		±2 dB
5	29 dBm		±2 dB

Table 1

A multi band MS has a combination of the power class in each band of operation from the table above. Any combination may be used. UK operators typically use power class 1 at 1800MHz and power class 4 at 900MHz.

---

<sup>1</sup> Reference: GSM 05.05

## Minimum Transmit Power

The minimum controlled output power of the MS is when the power is set to a minimum value. The minimum output power is as follows.

Band	Nominal Min Power	Tolerance
GSM 900	5 dBm	±5 dB
GSM 1800	0 dBm	±5 dB

Table 2

## Terminal Multi-slot Classes

Multi-slot Class numbers define the combination of receive and transmit time slots that a terminal can operate at any time, it is worth noting the “Sum” column defines the total number of operating time slots.

Multislot class	Maximum number of slots		
	Rx	Tx	Sum
1	1	1	2
2	2	1	3
3	2	2	3
4	3	1	4
5	2	2	4
6	3	2	4
7	3	3	4
8	4	1	5
9	3	2	5
10	4	2	5
11	4	3	5
12	4	4	5

Table 3

Multi-slot classes 13-29 cover conditions up to 8 Rx and 8 Tx with no “Sum” limit.

## Terminal Operational Classes

- Class A** Capable of simultaneous Voice and Data transmission.  
*Currently<sup>2</sup> there may not be any of these on the market.*
- Class B** Capable of either Voice **or** Data  
*Currently<sup>2</sup> these account for the majority of terminals on the market.*
- Class C** Data only devices.  
*Currently<sup>2</sup> Class C terminals are not often developed as Class B is often utilised.*

---

<sup>2</sup> As of end of February 2002

# 3<sup>rd</sup> Generation Partnership Project: Technical Specification Group GSM/EDGE Radio Access Network; Multiplexing and multiple access on the radio path (Release 1997)

## Operational States:

Off or Idle	The terminal is either powered down or out of the service area.
Standby	Periodic communications with the base station to provide a "Location Update" equivalent communication, as well as updates on moving between cells, updates are more frequent than GSM.
Active or Ready	The network is ready to send & receive data, radio resource has been allocated or is available.

## Multiple Services

During the operation of a data service, e.g. browsing the internet, a terminal will typically be assigned one uplink timeslots and multiple down link time slots. There are three possible results if a voice call is received by this terminal:

- The terminal may drop the data call to accept the voice call.
- The terminal may switch to half-rate and continue the data service and accept the voice call.
- The voice call may be rejected, reporting the recipient terminal as not available.

## GPRS and SAR

For a GSM/GPRS terminal, a single transmit time slot GPRS data call would transmit the same average power as a full-rate, no-DTX GSM voice call and if used against the head would have the same SAR value reported. For GPRS terminals with additional transmit time slots, the maximum SAR would increase pro-rata.

The CENELEC terminal SAR compliance standard (EN50360) is applicable to a GPRS terminal when used against the ear, (e.g. includes a speaker & microphone within its body). The manufacturer should evaluate the maximum SAR with the maximum number of transmit time slots for that terminal active.

Standards are under development to address SAR compliance for hand-held and body worn usage. However, until these are available, the R&TTE Directive essential requirements still apply. The manufacturer must ensure "*the protection of the health and the safety of the user and any other person...*". This would have to be demonstrated according to best practice and would typically be based on compliance with the ICNIRP General Public guidelines.

## Wideband Code Division Multiple Access (WCDMA)

### Background

The general specification of WCDMA systems have been designed to deal with the efficient movement of much greater amounts of data than second generation systems. Some of the key requirements were defined as:

- Bit rates up to 2Mbps
- Variable bit rate to offer bandwidth on demand
- Multiplexing of services with different quality requirements on a single connection e.g. speech video and packet data
- Coexistence of second and third generation systems and inter-system handovers
- Support for asymmetric uplink and downlink traffic

# UK Spectrum Allocation

2110 – 2170 MHz – FDD Base transmit  
 1920 – 1980 MHz – FDD Base receive  
 1900 – 1920 MHz – Base transmit/receive in  
 Time Division Duplex

## License Allocation

- License A: Hutchison3G
- License B: Vodafone
- License C: O2
- License D: T-Mobile
- License E: Orange

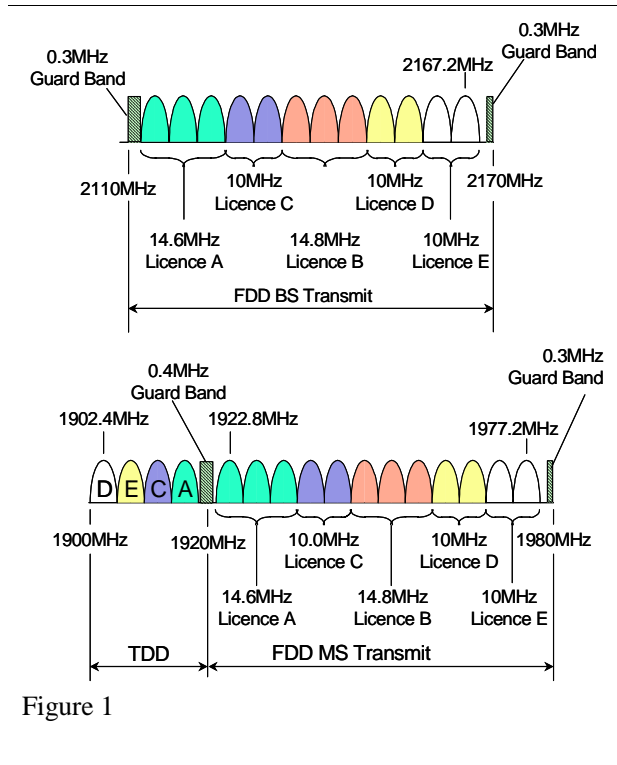

Figure 1

## The Standards

3<sup>rd</sup> generation mobile systems are based on the Global 3GPP (3<sup>rd</sup> Generation Partnership Project) standards and are commonly referred to as Universal Mobile Telecommunications Systems, or UMTS. 3GPP has created radio standards for two different modes of operation: TDD & FDD. Both modes of operations are designed to carry both voice and data transmissions.

- Time Division Duplex (TDD)
- Frequency Division Duplex (FDD)

### Operational Considerations

Operationally, ubiquitous UK coverage is to be provided by FDD mode equipment. It is currently envisioned that the TDD mode equipment will be deployed minimally at localised dense traffic areas where high data throughput is required.

### Frequency Division Duplex

The FDD technology is based on a Direct Sequence Code Division Multiple Access (DS-CDMA) or WCDMA and operates over a 5MHz bandwidth.

Parameter	Value
Technology	Direct Sequence Code Division Multiple Access (DS-CDMA)
Modulation scheme	Quadrature Phase Shift Keying (QPSK)
System bandwidth	4.4 – 5 MHz, 200kHz carrier raster
Chipping rate	3.84 Mchips/second

## Exposure Aspects of FDD

### Modulation<sup>3</sup>

The modulation scheme employed is QPSK, Quadrature Phase Shift Keying. In WCDMA the two uplink dedicated physical channels are I-Q/code multiplexed to provide a continuous transmission where no pulsed transmission occurs. The terminal is optimised to have as low a peak-to-average (PAR) ratio as possible.

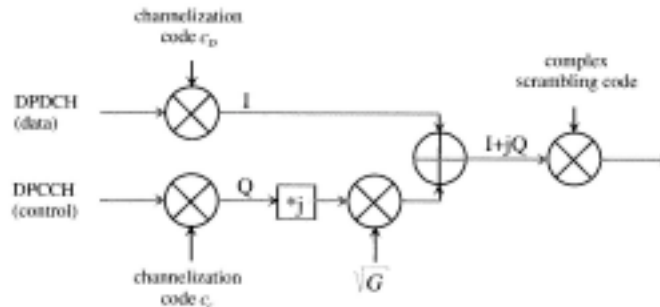

Figure 2 – Example of UpLink Multiplexing

### Minimum Transmit Power

The minimum controlled output power of the UE is when the power is set to a minimum value which shall be less than  $-50$  dBm.

### Power Class<sup>4</sup> (maximum power)

3G user equipment (UE transmitter) or mobile phone handsets are limited to the following maximum power outputs. The UE transmitter, dependent upon the operator, will generally limit the data transmissions to power class 3 and voice transmissions to power class 4.

Power Class	Nominal Max Power	Tolerance
1	33 dBm	+1/-3 dB
2	27 dBm	+1/-3 dB
3	24 dBm	+1/-3 dB
4	21 dBm	$\pm 2$ dB

Table 4 - UE Power Class

### Inner Loop Power Control<sup>5</sup>

Inner loop power control procedure is initiated once a communications link has been set up. Inner loop power control in the UpLink is the ability of the UE transmitter to adjust its output power in accordance with one or more TPC\_cmd (Transmit Power Control command) received in the downlink. As can be seen in Figure 3, there is one TPC\_cmd per time slot resulting in a 1500 Hz command rate.

<sup>3</sup> Reference: 3GPP TS 25.213

<sup>4</sup> Reference: 3GPP TS 25.101

<sup>5</sup> Reference: 3GPP TS 25.101

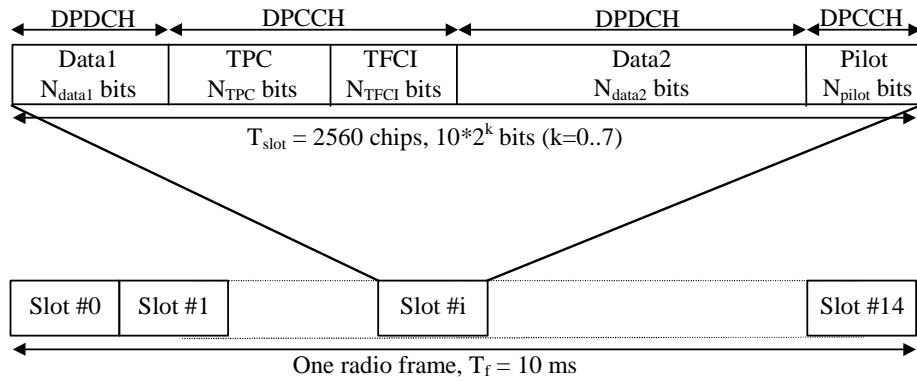

**Figure 3 - Downlink frame structure for DPCH**<sup>6</sup>

The UE transmitter has the capability of changing the output power with a step size of 1, 2 and 3 dB in the slot immediately after the TPC\_cmd. The relative accuracy of each basic step size is given in Table 5.

TPC_cmd	Transmitter power control range					
	1 dB step size		2 dB step size		3 dB step size	
	Lower	Upper	Lower	Upper	Lower	Upper
+ 1	+0.5 dB	+1.5 dB	+1 dB	+3 dB	+1.5 dB	+4.5 dB
0	-0.5 dB	+0.5 dB	-0.5 dB	+0.5 dB	-0.5 dB	+0.5 dB
-1	-0.5 dB	-1.5 dB	-1 dB	-3 dB	-1.5 dB	-4.5 dB

**Table 5 - Accuracy of power control steps**<sup>7</sup>

<sup>6</sup> Reference: 3GPP TS 25.211

<sup>7</sup> Reference: 3GPP TS 25.101